

DATE

REVISIONS

REV

DRAWING NUMBER
SSL-LXA227GD-5V

REV

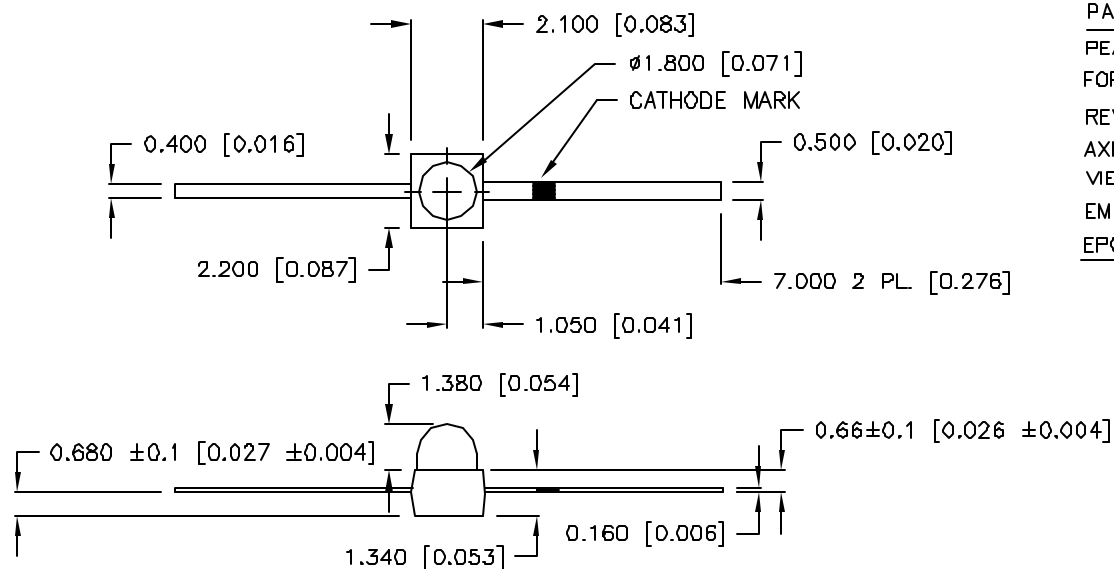
ELECTRO-OPTICAL CHARACTERISTICS TA=25 °C I_f=20mA

PARAMETER	MIN	TYP	MAX	UNITS	TEST COND
PEAK WAVELENGTH		565 (GREEN)		nm	
FORWARD VOLTAGE		5.0	7.0	V _f	
REVERSE VOLTAGE	5.0			V _r	I _r =100μA
AXIAL INTENSITY		8		mcd	I _f =20mA
VIEWING ANGLE		60		2x theta	
EMITTED COLOR:		GREEN			
EPOXY LENS FINISH:		GREEN DIFFUSED			

LIMITS OF SAFE OPERATION AT 25 DEG. C

PARAMETER	MAX	UNITS
PEAK FORWARD CURRENT *	160	mA
STEADY CURRENT	30	mA
POWER DISSIPATION	100	mW
DERATE FROM 25 °C	-1.2	mW/°C
OPERATING, STORAGE TEMP.	-40 TO +85	°C
LEAD SOLDERING TEMP.	+260	°C
2.0mm FROM BODY		3 SEC. MAX

* t<10μs

RELIABILITY NOTE:

OUR MANY YEARS OF EXPERIENCE DATA ACCUMULATION INDICATE THAT SOLDER HEAT IS A MAJOR CAUSE OF EARLY AND FUTURE FAILURE. PLEASE PAY ATTENTION TO YOUR SOLDERING PROCESS.

LUMEX
OPTO COMPONENTS INC.

292 E. HELLEN ROAD
PALATINE, ILLINOIS 60067
(708) 359-2790

DATE: 7-12-95

APPROVED BY:

DRAWN BY:

SCALE: N/A

AXIAL LED, GREEN DIFFUSED. WITH INTEGRAL 5V RESISTOR

PAGE 1 OF 1

DRAWING NUMBER
SSL-LXA227GD-5V

REV

LXA223AK